

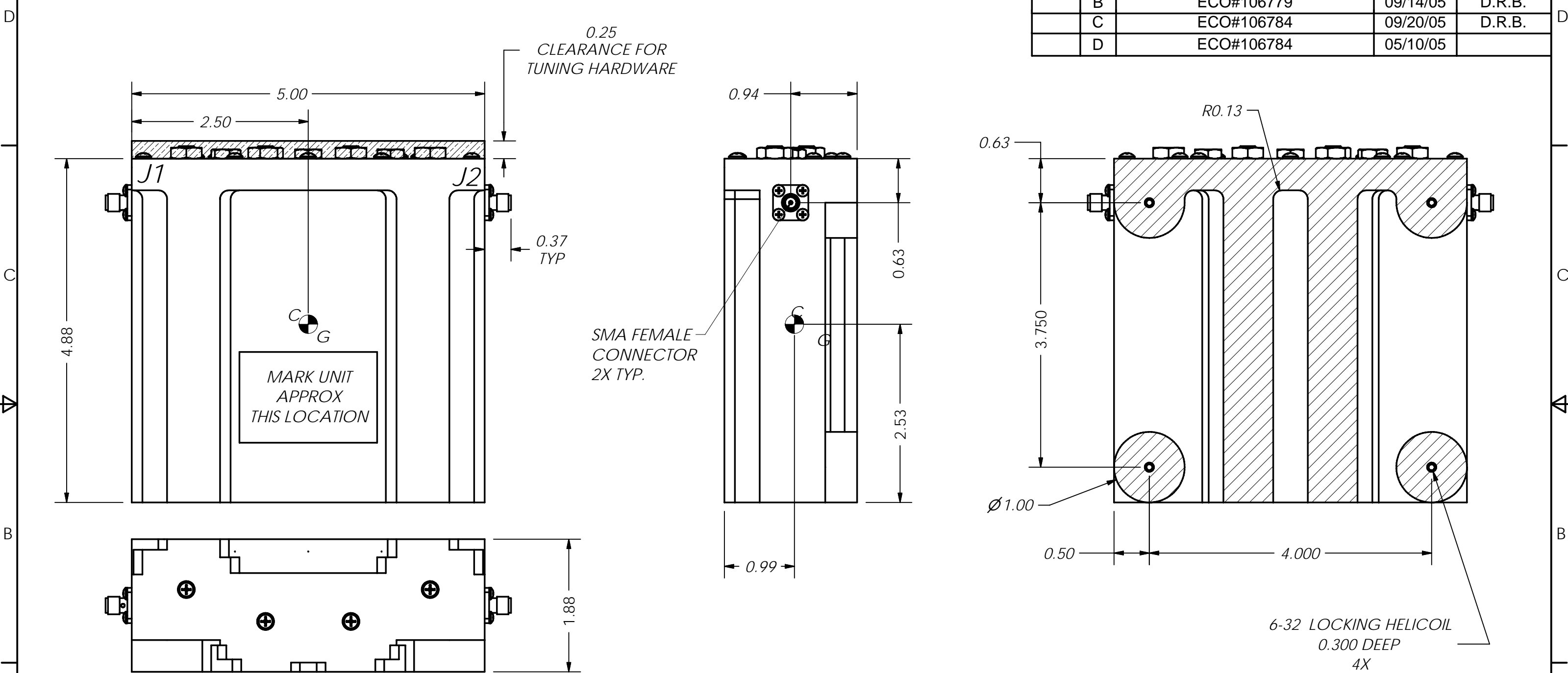

THIS DOCUMENT CONTAINS INFORMATION PROPRIETARY TO DELTA MICROWAVE. ANY REPRODUCTION WITHOUT WRITTEN PERMISSION IS EXPRESSLY PROHIBITED.

ZONE	REV	DESCRIPTION	DATE	APPROVED
	A	RELEASED	09/07/05	D.R.B.
	B	ECO#106779	09/14/05	D.R.B.
	C	ECO#106784	09/20/05	D.R.B.
	D	ECO#106784	05/10/05	



4. UNIT WEIGHT <2.0 LBS
3. HATCH AREAS TO REMAIN FREE OF PAINT
FINISH IS CHEM FILM PER MIL-C-5541E CLASS 3
2. MARKING: USING LABEL OR BLACK WARNOW INK TO INCLUDE:
DELTA MICROWAVE, MODEL NO., SERIAL NO.,
CODE IDENT. NO. 51719 AND DATE CODE
1. FINISH: HAZE GRAY EPOXY POLYAMIDE TOPCOAT
PER MIL-DTL-24441C, SUP.1
MIL-DTL-24441/21, TYP 3, FORMULA 151
USING GREEN EPOXY POLYAMIDE PRIMER
MIL-DTL-24441/20, TYP 3, FORMULA 150

NOTES:

UNLESS OTHERWISE SPECIFIED DIMENSIONS ARE IN INCHES TOLERANCES ARE: FRACTIONS DECIMALS ANGLES + .xx ± .03 + - .xxx ± .005 -		CONTRACT NO. U14115		 Delta Microwave Inc. 1301 VANGUARD DRIVE OXNARD, CA 93033	
APPROVALS		DATE			
DRAWN D.F. ESTABROOK		09/07/05		U14115 OUTLINE	
REVISD D.F. ESTABROOK		09/14/05			
MATERIAL CASE MATERIAL 6061-T6 ALUMINUM ALLOY		CHECKED		SIZE CODE IDENT NO. DWG NO.	
FINISH SEE NOTE 1 AND 3		APPROVED		B 51719 U14115	
USED ON MODEL#		DO NOT SCALE DRAWING		SCALE 3/4 SHEET 1 OF 1	