

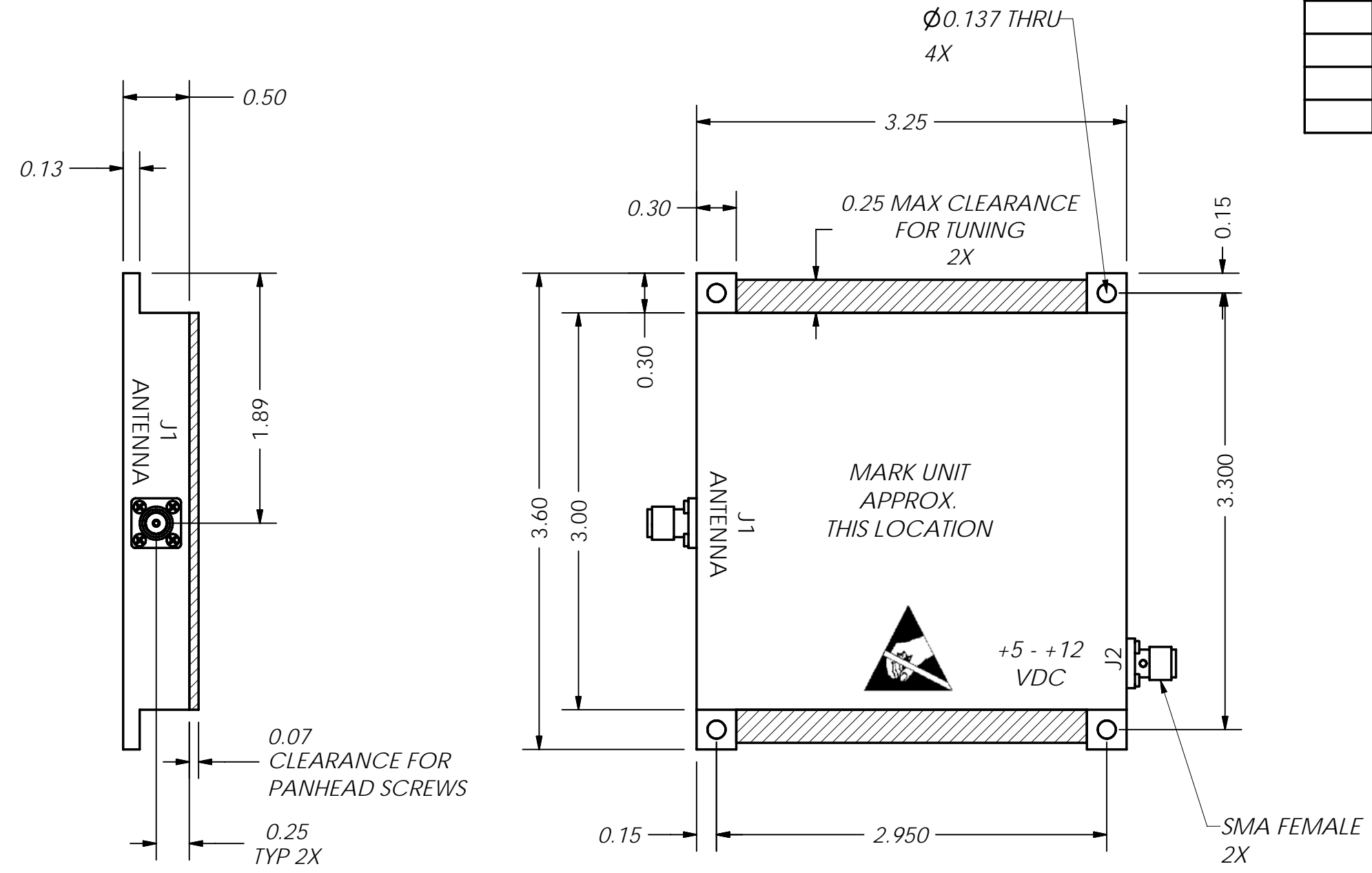

THIS DOCUMENT CONTAINS INFORMATION PROPRIETARY TO DELTA MICROWAVE. ANY REPRODUCTION WITHOUT WRITTEN PERMISSION IS EXPRESSLY PROHIBITED.

ZONE	REV	DESCRIPTION	DATE	APPROVED
	A	RELEASED	07/09/04	R.E.S.
	B	ADDED SMA CONNECTORS	07/29/03	D.R.B.
	C	SHOW HATCH FOR CLEARANCE	08/07/03	D.R.B.
	D	ECO#106772	08/25/05	D.R.B.
	E	ECO#106774	08/29/05	D.R.B.
	F	ECO#106937	04/06/06	



2. MARKING: USING BLACK WARNOW INK TO INCLUDE DELTA MICROWAVE, MODEL NO., SERIAL NO. CODE IDENT. NO. 51719 AND DATE CODE
1. FINISH: HAZE GRAY EPOXY POLYAMIDE TOPCOAT PER MIL-P-24441B TYP. 1 (AS) COLOR NO. 26270, FORMULA 151 PER MIL-P-24441/1C, QPL 24441-103 USING EPOXY POLYAMID PRIMER PER MIL-P-2441B TYP. 1 24272 GREEN FORMULA 150 PER MIL-P-24441/1C, QPL 24441-103

NOTES:

UNLESS OTHERWISE SPECIFIED DIMENSIONS ARE IN INCHES TOLERANCES ARE: FRACTIONS DECIMALS ANGLES + .xx ± .03 + - .xxx ± .010 -	CONTRACT NO. L5373		 Delta Microwave Inc. 1301 VANGUARD DRIVE OXNARD, CA 93033
	APPROVALS	DATE	
	MATERIAL	REVISIONS	TITLE
	FINISH	CHECKED	
USED ON MODEL#	DO NOT SCALE DRAWING	APPROVED	SIZE B CODE IDENT NO. 51719 DWG NO. L5373 SCALE 1:1 SHEET 1 OF 1